

ASSEMBLY INSTRUCTIONS







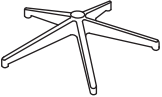

1.

2.

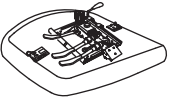
3.

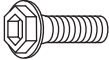
4.

5.

A.  5 PCS	B.  1 PC
C.  1 PC	D.  1 PC
E.  1 PC	F.  1 PAIR
G.  5/16"x3/4" 3 PCS	H.  2 PCS
I.  3 PCS	J.  1 PC

Model: ALE-HPM4201/HPM4202/HPT4201
 Manufactured for/ Hecho para/ Fabriqué pour Alera®/ Essendant Co.,
 One Parkway North, Deerfield, IL 60015 © 2016 Essendant Co.
 Made in/ Hecho en/ Fabriqué en China
 Product support and parts: 1-800-733-4000
 Ayuda del producto y partes / Support technique et pieces

OPERATING INSTRUCTIONS

Model: ALE-HPM4201/HPM4202/HPT4201

A. Seat height adjustment

To raise the seat height, stand up from the chair while lifting the lever (A) under the right side of the seat. To lower the seat height, lift the lever (A) while sitting in the chair.

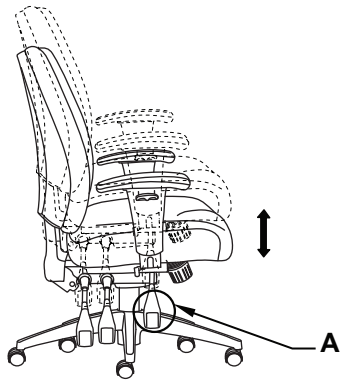

B. Seat angle adjustment

Put down the lever (B), Random lean back will cause the chair seat to tilt backwards. Raise the lever (B) to lock the chair back and seat at random position.

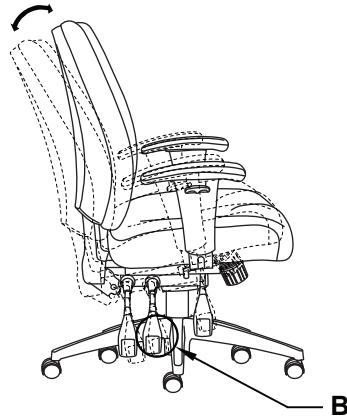

C. Back angle adjustment

Push the lever (C) upward. Leaning back will cause the chair back to tilt backwards. Push the lever (C) downward. To lock the chair back in the upright, vertical position or sit upright.

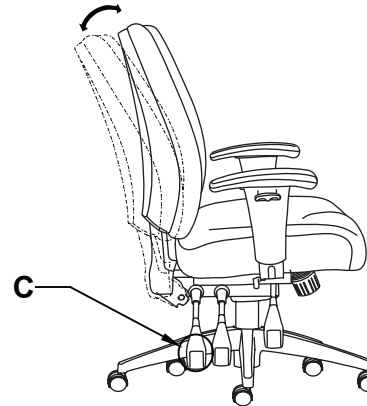

D. Backrest height adjustment

To raise the back, pull up on the seat back until it clicks into the desired height. To lower the back, raise the seat back all the way up until tension is released and then lower all the way down. Raise back up to desired position.

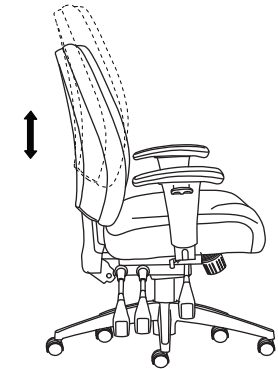

E. Sliding seat adjustment

Push the lever (E) upward to allow seat to slide forward or backward. Release handle to lock in desired seat position

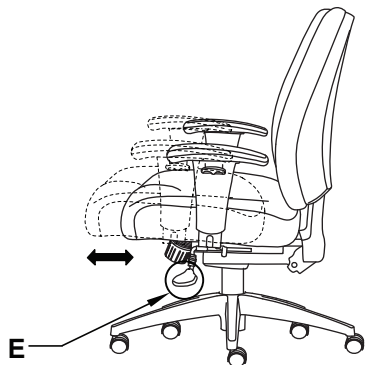

F. Arm height adjustment

To adjust arm height, push the button on the outside of each arm and move the arm up or down. Release the button to set the height.

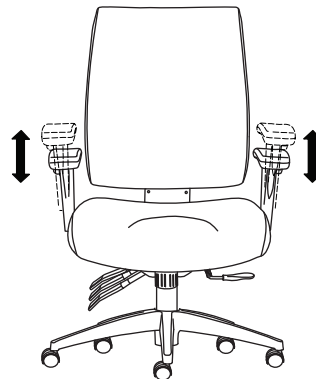

G. Arm width adjustment

To adjust arm width, loose the switch underneath seat pan on both sides of chair arms. Tighten the switch to fix the width of armrests.

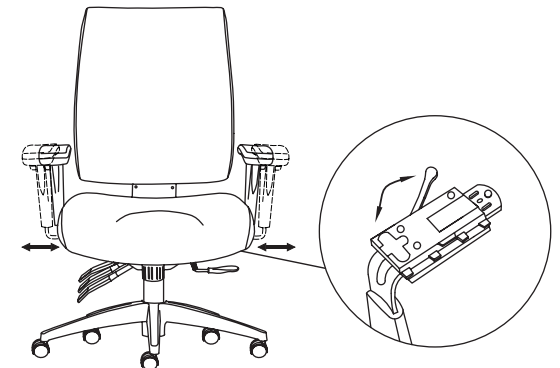

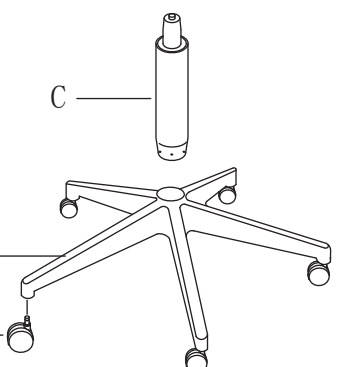

INSTRUCCIONES DE INSTALACIÓN

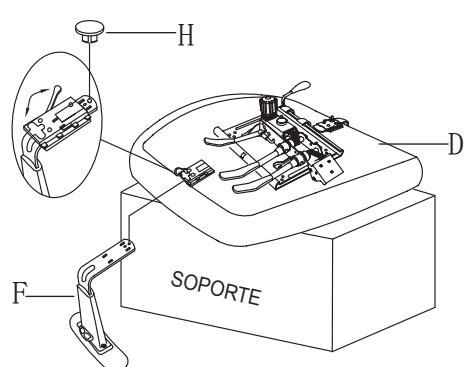
1. 

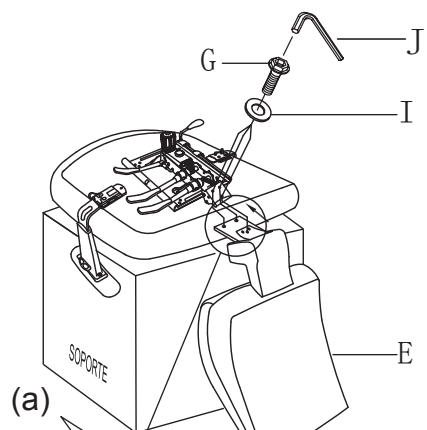
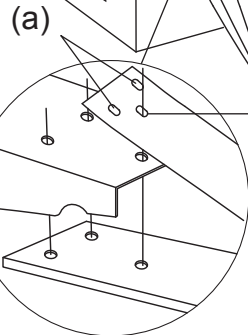
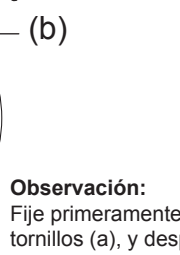

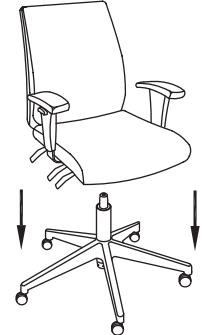





2. 

3. 

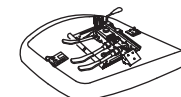

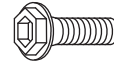
4. 

5. 

Observación:
 Fije primeramente los tornillos (a), y después fije el tornillo (b).

A.  5 PZS	B.  1 PZ
C.  1 PZ	D.  1 PZ
E.  1 PZ	F.  1 PAR
G.  5/16" x 3/4" 3 PZS	H.  2 PZS
I.  3 PZS	J.  1 PZ

Modelo: ALE-HPM4201/HPM4202/HPT4201
 Manufactured for/ Hecho para/ Fabriqué pour Alera®/ Essendant Co.,
 One Parkway North, Deerfield, IL 60015 © 2016 Essendant Co.
 Made in/ Hecho en/ Fabriqué en China
 Product support and parts: 1-800-733-4000
 Ayuda del producto y partes / Support technique et pieces

INSTRUCCIONES OPERATIVAS

Modelo: ALE-HPM4201/HPM4202/HPT4201

A. Altura del asiento

Para elevar la altura del asiento, póngase de pie mientras levanta la palanca "A", bajo el lado derecho del asiento. Para reducir la altura del asiento, eleve la palanca "A" mientras se va sentando.

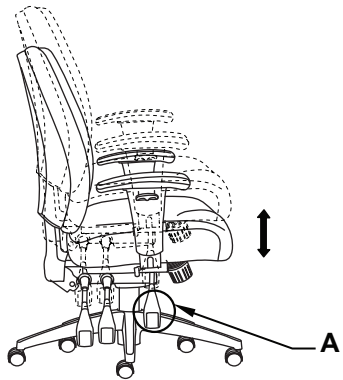

B. Ajuste del ángulo del asiento

Ponga hacia abajo la palanca (B), Reclinarse aleatoriamente hará que el asiento de la silla se incline hacia atrás, Levante la palanca (B) para bloquear el respaldo de la silla y sentarse en posición aleatoria.

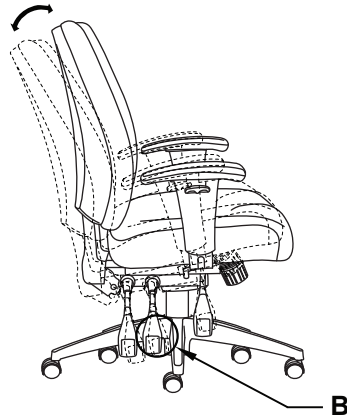

C. Ajuste del ángulo del respaldo

Presione la palanca (C) hacia arriba. Reclinarse hacia atrás hará que el respaldo de la silla se incline hacia atrás. Presione la palanca (C) hacia abajo para bloquear el respaldo de la silla en la posición erguida, vertical o sentarse erguido.

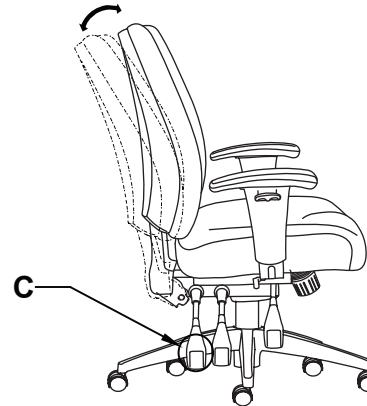

D. Ajuste de la altura del respaldo

Para levantar el respaldo, tire del respaldo hacia arriba hasta que haga clic en la altura deseada. Para bajar el respaldo, levante el respaldo totalmente hasta que se libere tensión y luego baje totalmente. Levante el respaldo hacia la posición deseada.

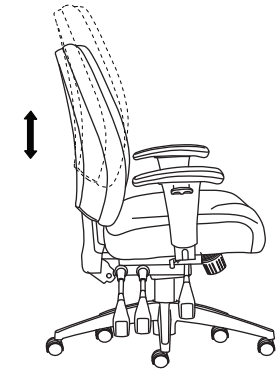

E. Ajuste del asiento deslizante

Presione la palanca (E) hacia arriba para permitir que el asiento se deslice hacia adelante o hacia atrás. Suelte la palanca para bloquear el asiento en la posición deseada.

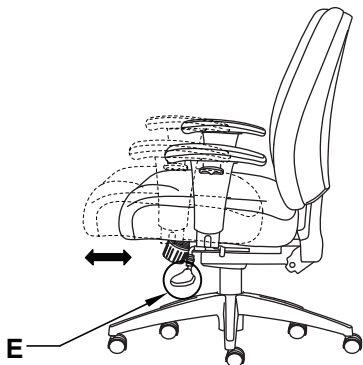

F. Ajuste de la altura del brazo

Para ajustar la altura del brazo, pulse el botón en la parte exterior de cada brazo y mueva el brazo hacia arriba o hacia abajo. Suelte el botón para fijar la altura.

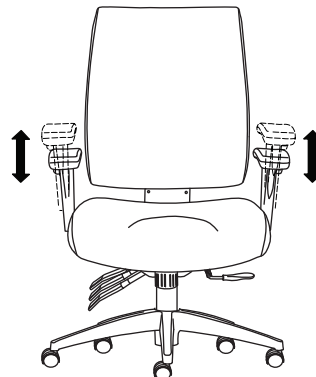

G. Ajuste del ancho del brazo

Para ajustar el ancho del brazo, afloje la perilla debajo del asiento a ambos lados de los brazos de la silla. Apriete la perilla para fijar el ancho de los reposabrazos.

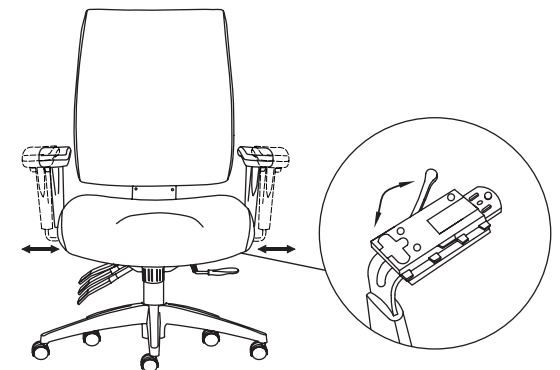

INSTRUCTIONS DE MONTAGE

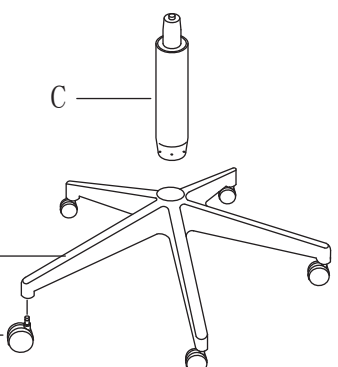
1. 

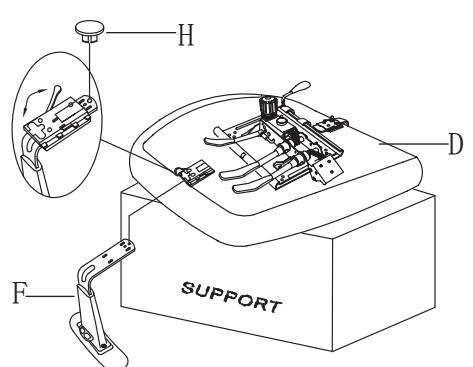

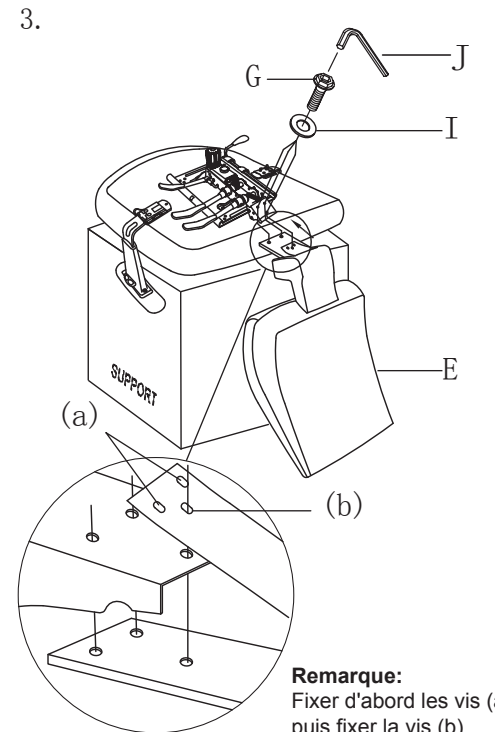



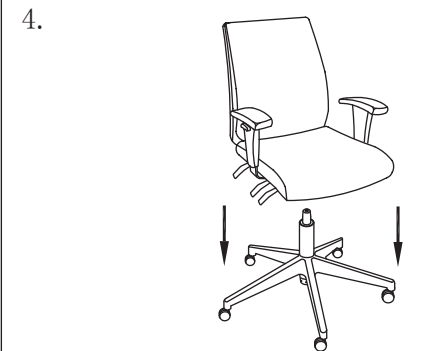

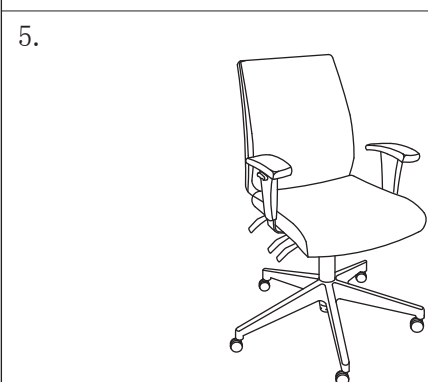
2. 

3. 

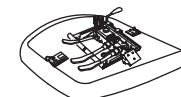
Remarque:
Fixer d'abord les vis (a), puis fixer la vis (b).

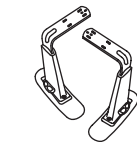
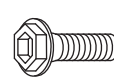
4. 

5. 

A.  5 PIECES	B.  1 PIECE
C.  1 PIECE	D.  1 PIECE
E.  1 PIECE	F.  1 PAIRE
G.  5/16"x3/4" 3 PIECES	H.  2 PIECES
I.  3 PIECES	J.  1 PIECE

Modèle: ALE-HPM4201/HPM4202/HPT4201
 Manufactured for/ Hecho para/ Fabriqué pour Alera®/ Essendant Co.,
 One Parkway North, Deerfield, IL 60015 © 2016 Essendant Co.
 Made in/ Hecho en/ Fabriqué en China
 Product support and parts: 1-800-733-4000
 Ayuda del producto y partes / Support technique et pieces

MODE D'EMPLOI

Modèle: ALE-HPM4201/HPM4202/HPT4201

A. La hauteur du siège

Pour élever la hauteur du siège, levez-vous de siège en soulevant le levier, 'A', sous le côté droit du siège. Pour baisser la hauteur du siège, soulever le levier, 'A', en restant assis sur le siège.

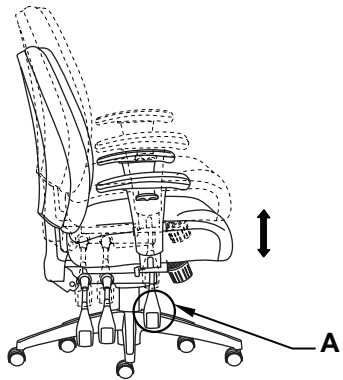

B. Réglage de l'inclinaison du siège

Baisser le levier (B), S'appuyer contre le dossier pour abaisser le siège vers l'arrière, Relever le levier (B) pour verrouiller le siège et vous assoir dans la position souhaité.

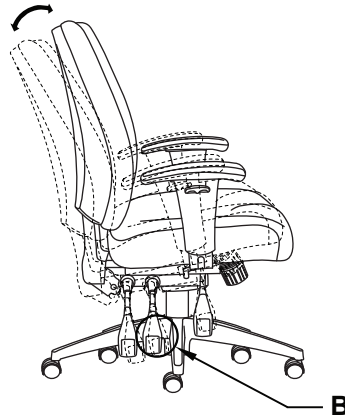

C. Réglage de l'inclinaison du dossier

Pousser le levier (C) vers le haut, s'appuyer contre le dossier pour abaisser le siège vers l'arrière. Pousser le levier (C) vers le bas, se redresser pour relever le dossier en position verticale.

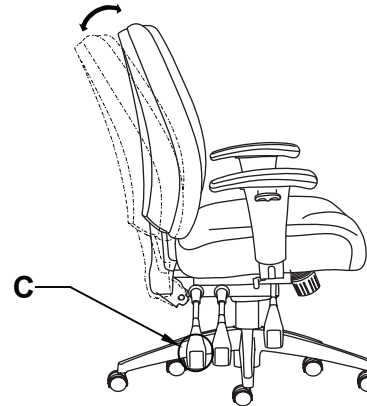

D. Réglage de la hauteur du dossier

Pour élever le dossier, tirer le vers le haut jusqu'à entendre le déclic à la hauteur désirée. Pour baisser le dossier, le monter au maximum jusqu'à ce que la tension soit relâchée et le baisser ensuite jusqu'en bas. Elever à nouveau le dossier jusqu'à la position voulue.

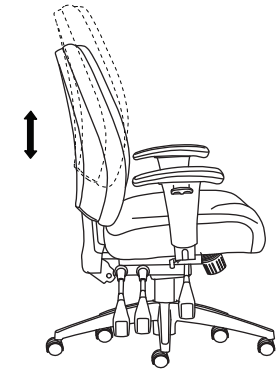

E. Réglage de l'avancement du siège

Pousser le levier (E) vers le haut pour permettre au siège de coulisser vers l'avant ou l'arrière. Relâcher le levier pour verrouiller le siège dans la position voulue.

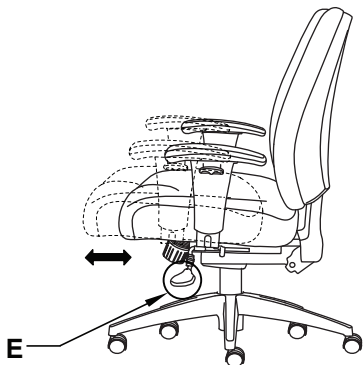

F. Réglage de la hauteur d'accoudoir

Pour régler la hauteur d'accoudoir, pousser le bouton situé sur l'extérieur de chaque accoudoir et déplacer l'accoudoir vers le haut ou le bas. Relâcher le bouton pour verrouiller la hauteur.

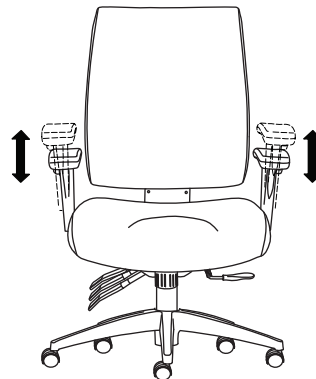

G. Réglage de l'écartement des accoudoirs

Pour régler l'écartement des accoudoirs, desserrer la manette située sous le siège des deux côtés des accoudoirs. Resserrer la manette pour fixer l'écartement des accoudoirs.

